

Product Data Sheet

Single 220 Series Gravimetric Powder Feeder

Oerlikon Metco's Single 220 series powder feeders offers the intrinsic precision of our volumetric feeders combined with the superior feed rate control of our gravimetric technology.

Consistent powder feed rate contributes directly to coating thickness repeatability. The Oerlikon Metco Single 220 utilizes cutting-edge gravimetric load-cell technology to deliver highly accurate feed rates. If desired, Single-220 series feeders can also be operated in standard volumetric powder feed mode.

Oerlikon Metco's Single-220 series powder feeders are designed for use with Oerlikon Metco MultiCoat thermal spray systems. The operator has complete control of and accessibility to all feed parameters via the MultiCoat Operator's Desk, which communicates directly with the Single 220. Multiple Single 220 powder feeders can be operated independently or simultaneously. Up to eight Single 220 feeders can be controlled using the MultiCoat system platform. Earlier generations of MultiCoat systems can use these feeders with the installation of a software update.

All of the powder hoppers designed for use with MultiCoat systems, such as the 1.5-liter acrylic and 5-liter aluminum hoppers, can be used with Single 220 powder feeders. Aluminum hoppers can be equipped with a heater, which requires the heating jacket for the hopper and the installation of the heater control unit. Single 220 feeders can be purchased with the heater option factory installed or field-retrofitted at a later date.

Customers can choose from four models of the Single 220 powder feeder, depending on the thermal spray process(es) that will be used:

Model	APS	CPS	HVOF	ChamPro
Single 220-A	✓	✓	✗	✗
Single 220-H	✗	✗	✓	✗
Single 220-AH	✓	✓	✓	✗
Single 220-V	✗	✗	✗	✓

APS: Atmospheric Plasma Spray
 CPS: Combustion Powder Spray
 HVOF: High Velocity Oxy-Fuel Spray (Liquid- or Gas-Fueled)
 ChamPro: Controlled Atmosphere Plasma Spray (LPPS, LVPS, VPS)

Single 220 series feeders use standard Oerlikon Metco powder feeder components, including suction/spreader bars, stirrers and disks. The wide range of options available allow customers to configure their feeder for their specific spray application.



Single 220-AH Powder Feeder shown with heater option installed.

1 Principle of Operation

Single 220 series powder feeders are equipped with a vibrating wire load cell, thereby basing the feed rate on a loss of weight principle that uses volumetric powder feeding technology and gravimetric feed rate control.

Single 220 series feeders can operate in either of two modes:

- **Volumetric Mode:** Powder is conveyed on a volume per unit time basis (open loop), with excellent accuracy and repeatability
- **Gravimetric Mode:** Powder is conveyed on a weight per unit time basis (closed loop) with superior accuracy and repeatability

When in gravimetric mode, the superior powder feed rate accuracy and repeatability is achieved through the acquisition and evaluation of measurement data:

- **Load Cell:** Transmits the powder weight to the measuring signal amplifier based on the vibrating wire principle.
- **Measuring Signal Amplifier:** Amplifies the signal received from the load cell and transmits it to the Processor and Control Printed Circuit Board (PCB).
- **Signal Processor:** Performs adaptive filtering and calculates the reduction of weight per unit of time. Using an advanced adaptive control algorithm, the powder feed rate is regulated by controlling the rotational speed of the powder disk. The calculated data is also sent to the PLC.
- **Programmable Logic Controller (PLC):** Communicates with the thermal spray controller and the Processor and Control PCB.

All parameters to operate the Single 220 feeder are accessible via the operator interface of the thermal spray controller (MultiCoat). These parameters can be stored as part of the spray recipe at the controller:

- Switching the metering disk on or off
- Setting the rotational speed of the metering disk
- Switching the stirrer on or off
- Setting the rotational speed of the stirrer
- Preselecting the carrier gas (argon or nitrogen)
- Switching the carrier gas on or off
- Setting the carrier gas flow
- Setting the powder feed rate

In addition, the spray controller monitors the feedback communications received from the powder feeder via the PLC:

- Metering disc rotational speed
- Stirrer rotational speed
- Carrier gas flow
- Powder feed rate

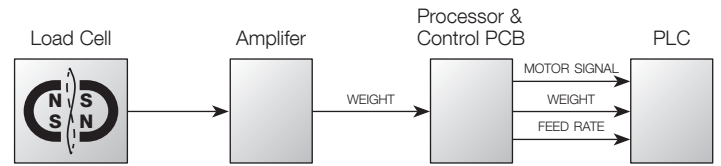

Single 220 Series Powder Feeders: Powder Weight Processing

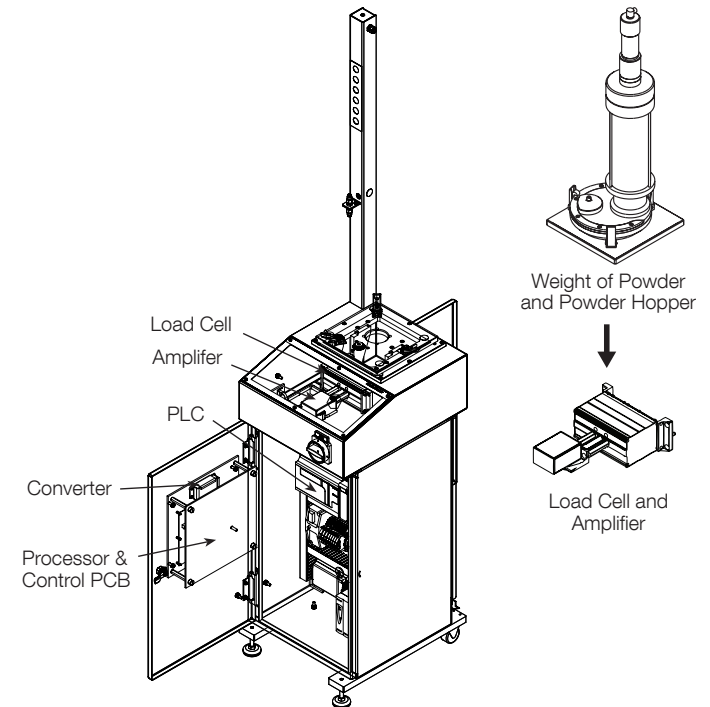

Single 220 Series Powder Feeders: Main Components

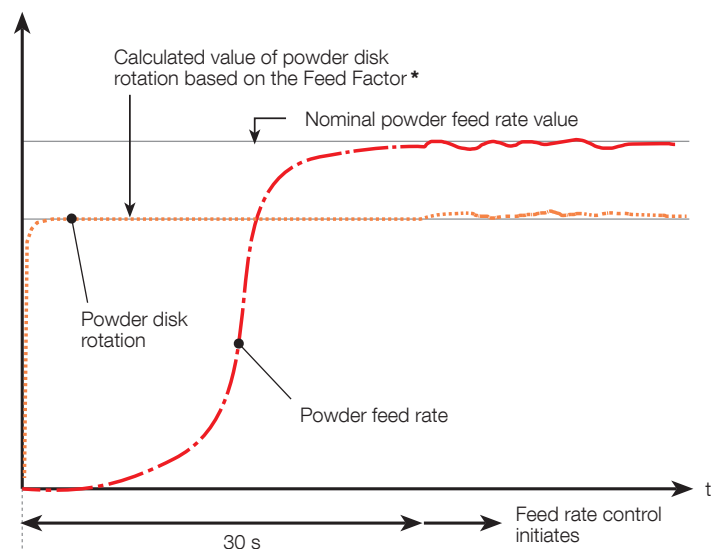

Single 220 Series Powder Feeders: Feed Rate Control Ramp-Up

* The Feed Factor is the proportional value of the feed rate versus disc speed for a given powder. Using this constant enables the feeder to quickly reach a stable feed rate.

2 Features and Benefits

- Excellent powder feed accuracy and repeatability based on gravimetric, rotating disk technology
- Accuracy is maintained throughout the spray run, even for extended spray campaigns,
- Gravimetric (feed rate control) or volumetric operation modes
- Fast feed rate stabilization time saves time and powder costs
- Feed rate is independent of the height of the powder in the hopper
- Feed rate is independent of the temperature
- Robustly insensitive to vibrations resulting from normal shop activity, air drafts and temperature changes
- While in volumetric operating mode, the gravimetric mode can monitor the feed rate using a preset tolerance
- Two-way communication with the controller maintains the powder feed recipe settings

3 Accessories and Options

Oerlikon Metco offers a wide variety of accessories and options for Single 220 series powder feeders to suit specific spray requirements. These include:

- Metering disks of different groove sizes and substrate materials
- Suction and spreader bars of different widths, heights and angles
- Stirrer configurations

For a complete list of optional parts and spare parts please refer to the parts lists section of the reference manual.

Powder Hoppers:

- 1.1 liter aluminum, may be equipped with heater jacket
- 1.5 liter acrylic
- 5.0 liter aluminum, may be equipped with heater jacket

Heater Option:

The heater option is recommended when using hygroscopic powders to prevent the powder from absorbing moisture. It consists of:

- Heating jacket for the powder hopper
- Temperature controller installed on the feeder console

Heaters can only be used with aluminum hoppers and must be chosen for the size of the hopper (1.1 or 5.0 liter)

Powder Quick-Switch Valve

Used to switch the powder flow from the powder feeder to either the spray gun or a powder collection container, should the spray process be interrupted, thus enabling a constant powder flow with no delay when restarting the spray process.

- Monitors low powder flow and the low levels (weight) of powder in the hopper; warning the operator via the controller interface
- Mass flow controlled carrier gas for stable gas flow across a wide range of operating parameters
- All powder feeder functions are controlled, set and monitored at the system controller, simplifying operation and spray parameter setup
- Feeds all types thermal spray powders, from very coarse through very fine particle sizes (5 µm to 200 µm)
- Highly configurable to the spray application requirements using the wide range of available optional components
- Simple, robust construction requires little maintenance and provides years of trouble-free service
- Designed for very safe operation; HVOF model is designed for high pressure operation

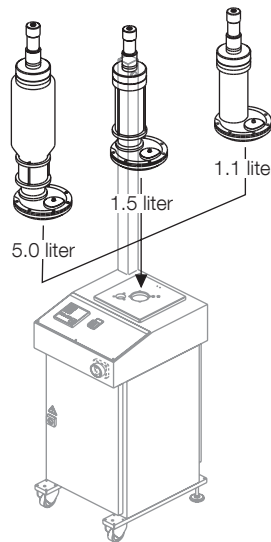

Powder Hopper Options for Single 220 Series Powder Feeders

Feeder Model	Available Hoppers
Single 220-A	1.1 Liter APS 1.5 Liter APS 5.0 Liter APS
Single 220-H	1.1 Liter HVOF 1.5 Liter HVOF 5.0 Liter HVOF
Single 220-AH	1.1 Liter APS 1.1 Liter HVOF 1.5 Liter APS 1.5 Liter HVOF 5.0 Liter APS 5.0 Liter HVOF
Single 220-V	1.1 Liter VPS 5.0 Liter VPS

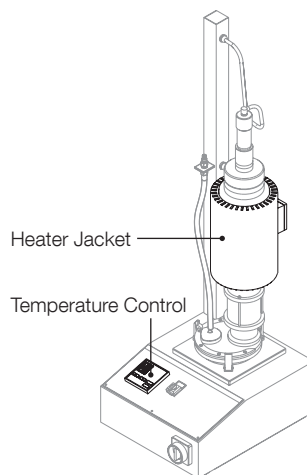

Heater Option

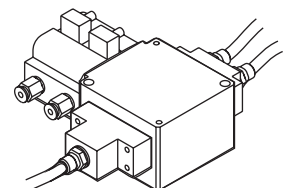

Powder Quick-Switch Valve

4 Technical Data

4.1 Dimensions

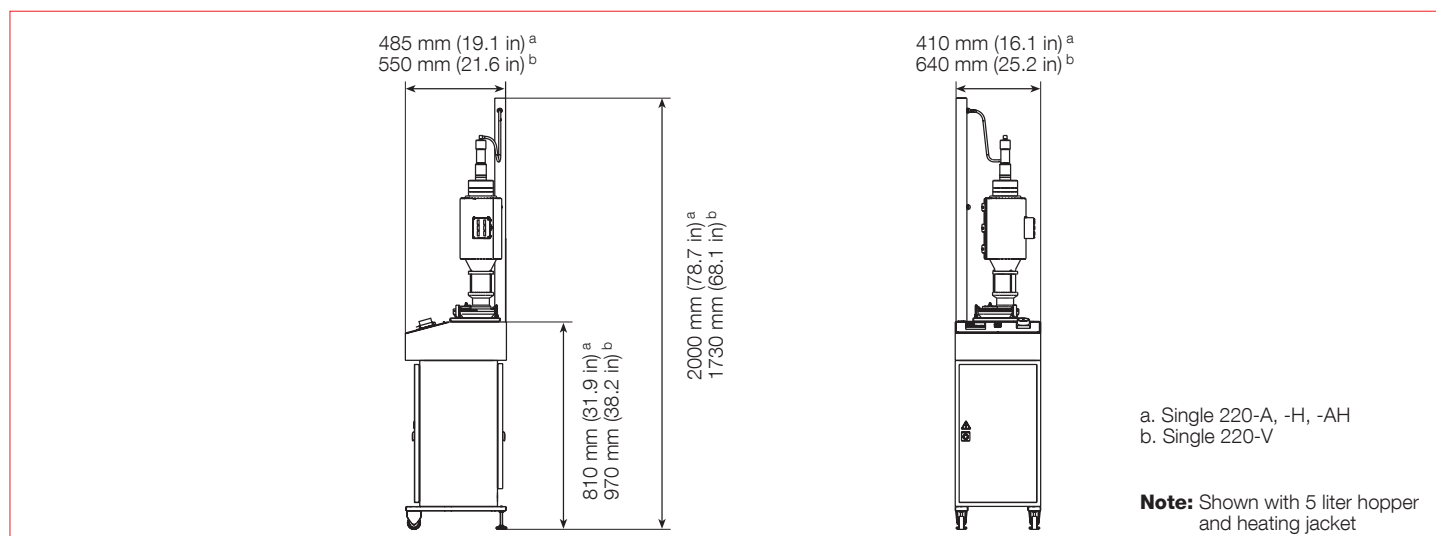

4.2 Specifications

Power Requirements			
Voltage		230 V	
Frequency		50 Hz	
Power Consumption	without heaters	0.25 kW	
	with heaters	0.75 kW	
Fusing		6 A	
Load Cell			
Type		Vibrating Wire	
Maximum Load		60 kg	132.3 lb
Resolution		15 mg	0.00053 oz
Carrier Gas			
Type		Argon or Nitrogen	
Connection	APS	3/8 in Swagelok	
	HVOF	1/2 in Swagelok	
Supply Pressure (min)	APS	3 bar	43.5 psi
	HVOF	9 bar	130.5 psi
Powder Feeding^a			
Feed Rate		5 to 150 g/min	0.7 to 19.8 lb/h
Feed Rate Deviation (max)		± 2 g/min	± 0.26 lb/h
Weight			
Without Hoppers		78 kg	168 lb
Operating Environment			
Temperature		+10 to +40 °C	+50 to +104 °F
Humidity		<75%, non-condensing	
Compatibility			
System Platform ^b		MultiCoat	
Spray Gun ^c		All Oerlikon Metco Spray Guns except 5MP-II	

a. With correct hopper, feeder hardware and parameters

b. Using the Single 220 powder feeder model that matches the system platform spray process(es)

c. Thermal spray guns using powder as the feedstock material

Information is subject to change without prior notice.